

Solid-State Lighting Series

EDIS Ellipse Module Datasheet

The elliptical reflector module is designed to offer wide beam angle parallel to road way. Depending on the luminous requirements, the modules can incorporate either single or multiple EdiStar emitters to achieve 50W and 100W.

Features :

- Solid State Lighting Technology
- Superior Quality Light
- Reduce CO₂Emission
- Energy Saving(50W/100W/120W)
- Ecologically Friendly
- Ellipse Type
- IP65

Typical Applications :

- High/Low Bay
- Outdoor Lighting
- Street Lighting





A Solid-State Lighting Premium Expert

Table of Contents

• Nomenclature.....	2
• Dimensions.....	3
• Absolute Maximum Ratings.....	3
• Specifications.....	3
• Electrical Specifications.....	4
• Illuminance Specifications.....	4
• Light Pattern.....	4
• Application.....	5
• Environmentally Friendly.....	6
• Package Information.....	9

Nomenclature

The following table describes the available colors, and angles.

EDIS - M 050 - W 2 0

X1		X2		X3		X4		X5		X6	
LED Item		Module		Power		Emitting Color		Reflector		Heatsink	
Code	Type	Code	Type	Code	Type	Code	Type	Code	Type	Code	Type
EDIS	Edison Integrated Soution	M	Module	050	50W	W	Cool White	2	Elliptical Reflector	0	Without Heatsink
				100	100W	H	Neutral White			3	Heatsink
				120	120W	X	Warm White				

Table 1 : EDIS ellipse module nomenclature.

Dimensions

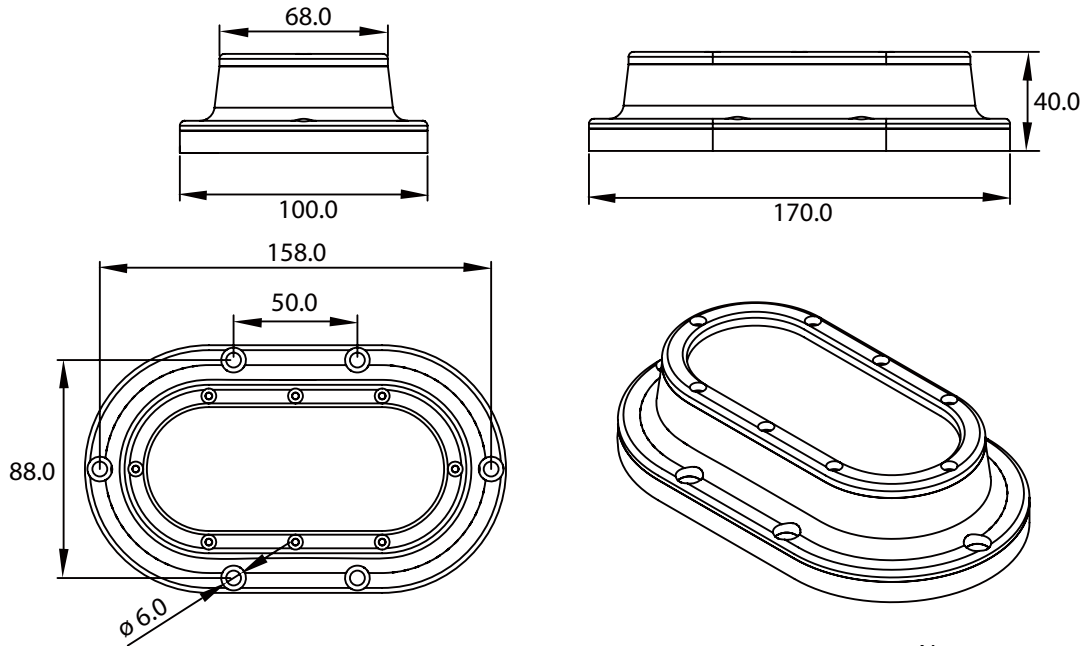

Figure 1 : EDIS ellipse module dimensions.

Notes:

1. Unit : mm.
2. Tolerance : ± 2.5 mm.

Absolute Maximum Ratings

The following table shows electrical characteristics and operating temperature of Circular Module.

Parameter	Symbol	Rating	Units
Operating Temperature	T_{opr}	-30 ~ 40	$^{\circ}\text{C}$
Storage Temperature	T_{stg}	-40 ~ 60	$^{\circ}\text{C}$
Using Ingress Protection (IP)		IP65	
LED Life Time		25,000	hrs

Table 2 : EDIS ellipse module absolute maximum ratings.

Specifications

The following describes the choices of color temperature, angles, and CRI of Circular Module for different demand.

Parameter	Rating	Units
Power Consumption	50 / 100 / 120	W
Field Angle	X:90 / Y:120	Degree
Color Temperature	5300~6300 / 3800~4500 / 2800~3200	K
CRI	70 / 75 / 80	/
Weight	625 \pm 5	g

Table 3 : EDIS ellipse module specifications.

Electrical Specifications

The following describes the electrical operating parameters.

Parameter	Power Consumption	Forward Voltage	Constant Current
EDIS-M050-x20	50W	24V	2.4A
EDIS-M100-x20	100W	33V	3.0A
EDIS-M120-x20	120W	33V	3.6A

Table 4 : EDIS ellipse module electrical specifications.

Illuminance Specifications

The tables present the illuminance level with respect to different color temperature.

Power Consumption	Parameter	CCT	Field Angle	Flux (Typ.)	lux@1m (Typ.)
50W	EDIS-M050-W20	5300~6300K	X:90 / Y:120	3000 lm	1200 lux
	EDIS-M050-H20	3800~4500K	X:90 / Y:120	2700 lm	1100 lux
	EDIS-M050-X20	2800~3200K	X:90 / Y:120	2500 lm	900 lux
100W	EDIS-M100-W20	5300~6300K	X:90 / Y:120	5500 lm	2300 lux
	EDIS-M100-H20	3800~4500K	X:90 / Y:120	4600 lm	1800 lux
	EDIS-M100-X20	2800~3200K	X:90 / Y:120	4000 lm	1600 lux
120W	EDIS-M120-W20	5300~6300K	X:90 / Y:120	7000 lm	2900 lux
	EDIS-M120-H20	3800~4500K	X:90 / Y:120 </td <td>5700 lm</td> <td>2200 lux</td>	5700 lm	2200 lux
	EDIS-M120-X20	2800~3200K	X:90 / Y:120	5000 lm	2000 lux

Table 5 : EDIS ellipse module illuminance specifications.

Light Pattern

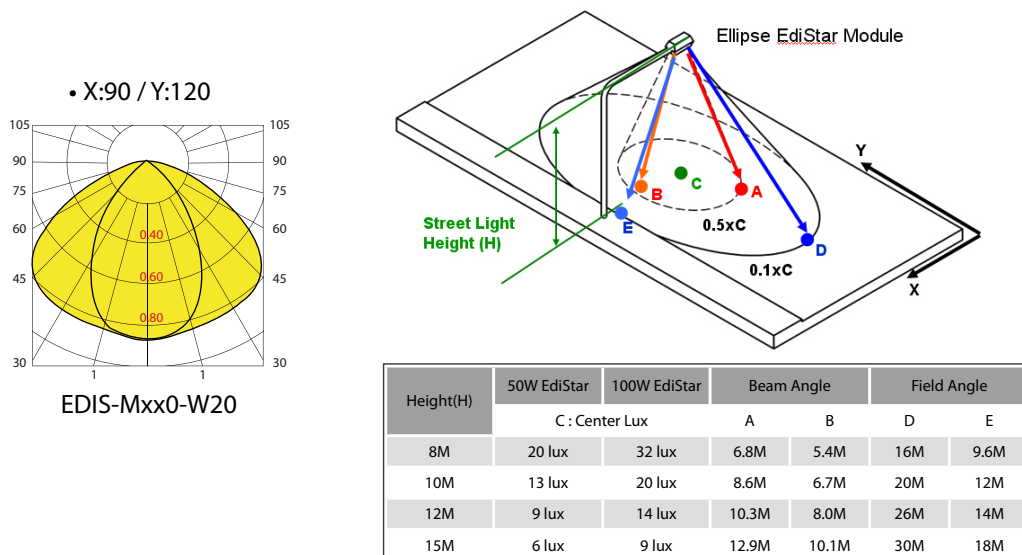

Figure 2 : EDIS ellipse module light pattern.



A Solid-State Lighting Premium Expert

Application

The ellipse module is designed to offer wide beam angle parallel to road way and wall washer and Tunnel lights.

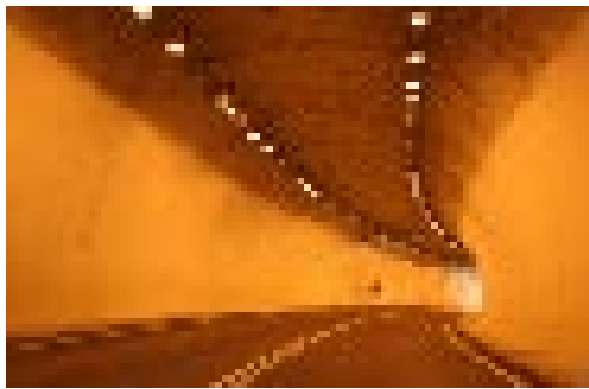

Table 4 : EDIS ellipse module application.

Environmentally Friendly

With the increasing demand for energy and the effect on global warming, Edison Opto plays a role in preserving the forest by reducing energy consumption, and CO2 emission one step at a time.

Replacing traditional mercury vapor lamp with Ediosn Opto EdiStar Module lighting application, one can help in reducing global warming by lots of CO2 annually.

50W EDIS Module VS 100W Mercury Vapor Lamp

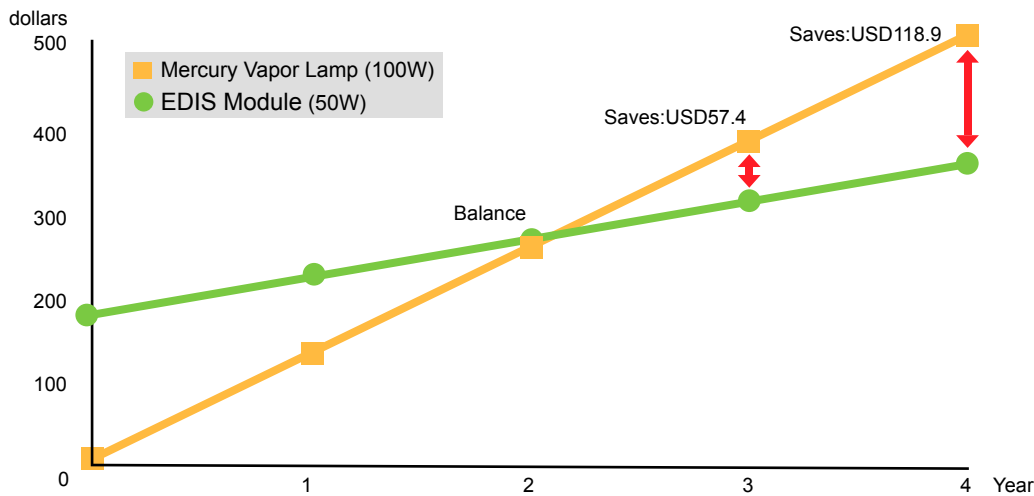
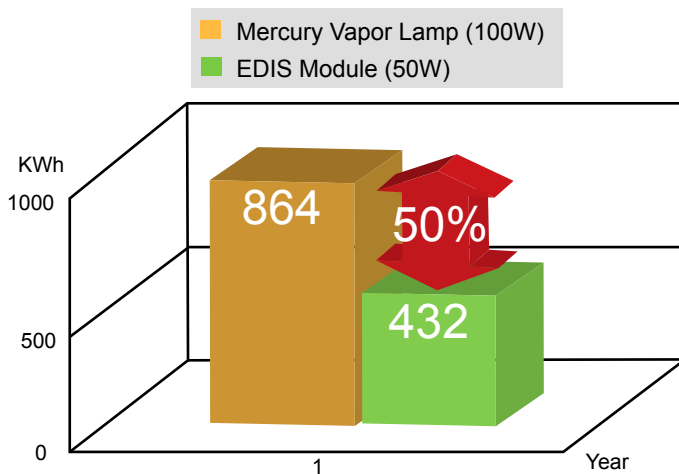
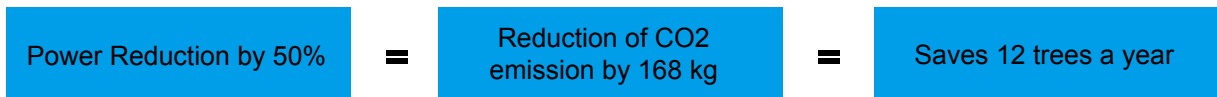

Figure 5 : 50W EDIS Module VS 100W Mercury Vapor Lamp.

Note : Calculation based on 24 hours of daily operation.



A Solid-State Lighting Premium Expert

Environmentally Friendly

100W EDIS Module VS 250W Mercury Vapor Lamp

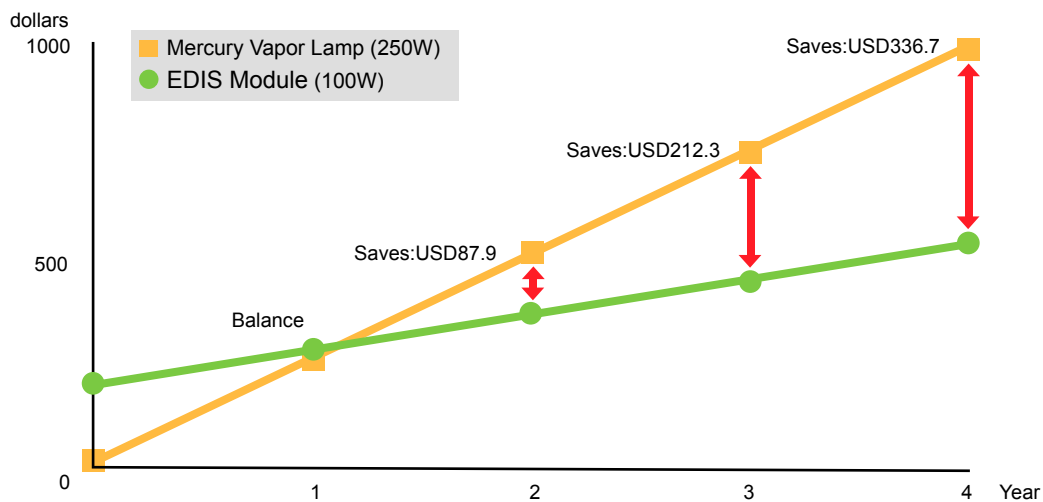
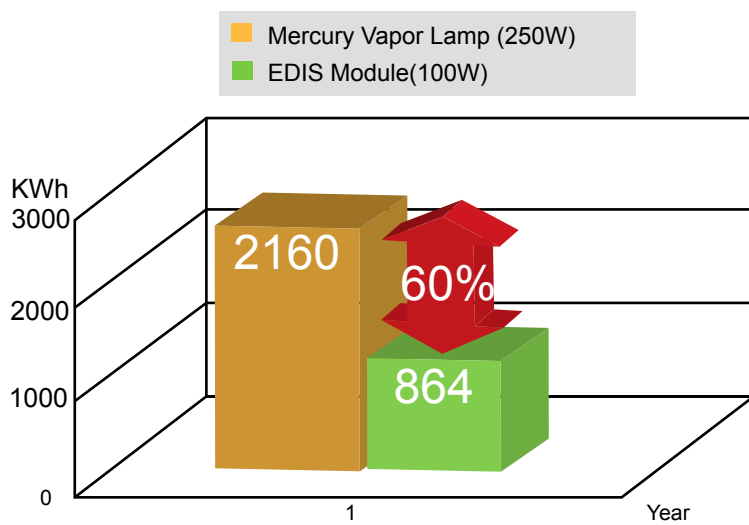
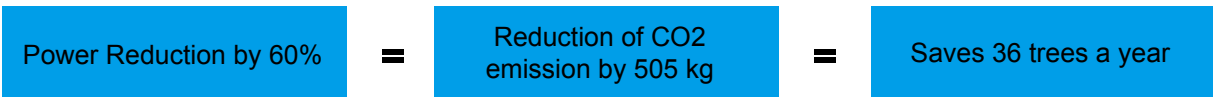

Figure 6 : 100W EDIS Module VS 250W Mercury Vapor Lamp.

Note : Calculation based on 24 hours of daily operation .

Environmentally Friendly

120W EDIS Module VS 400W Mercury Vapor Lamp

Power Reduction by 70% = Reduction of CO2 emission by 1286 kg = Saves 92 trees a year

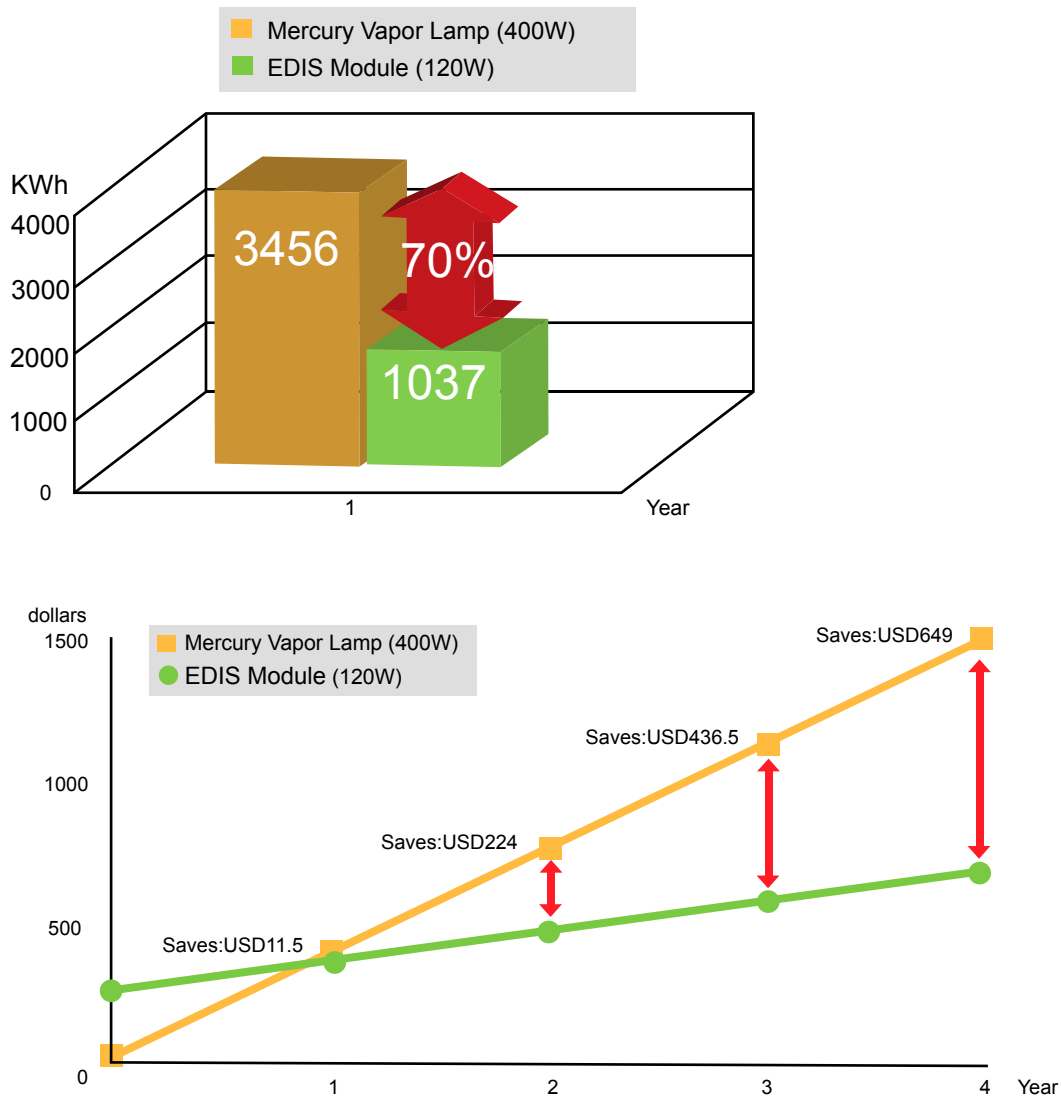
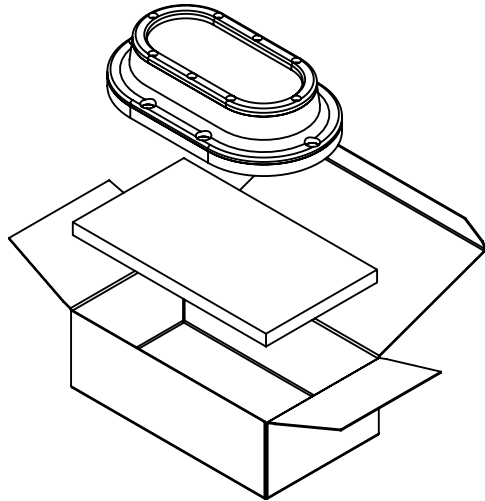

Figure 7 : 120W EDIS Module VS 400W Mercury Vapor Lamp.

Note : Calculation based on 24 hours of daily operation .

Package Information



1pc / Pack

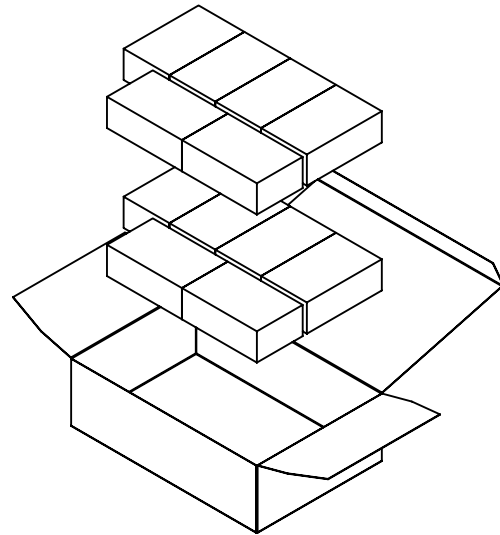

12 Packs / Carton

Figure 9 : EDIS ellipse Module Package Information.

Notes:

1. Every Circular Module comes with a set of accessories including four socket head cap screws(M5) and one thermal pad (K=3W/mK).
2. Pack Dimensions : 177m(length)*103mm(width)*60mm(height)
3. Carton Dimensions: 446mm(length)*300mm(width)*140mm(height)